



Carbon Monoxide Transmitter

Model : CO-T1(D)

PRODUCT DESCRIPTION

Most building codes require a very high ventilation rate in enclosed parking or in areas involving vehicle repairs and operation. This must be provided during all hours of use. Most codes allow fans to be operated intermittently or complete shut-off as long as the carbon monoxide (CO) concentration in the space does not exceed 25 or 50ppm (check local code). A CO sensor can be used to reduce fan energy costs by switching off or reducing fan speed when CO level is low

The CO-T1 is a simple CO sensor/transmitter designed specifically for these applications. It delivers all the advantages of electrochemical sensing in a durable, long life (5-year) package and at attractive low price. The 2-wire loop powered sensor delivers a linear 4~20mA output that is easily integrated into any building control, ventilation or alarm system.



CO-T1
Wall mount model



CO-T1D
wall mount model
with LC Display

FEATURES

- Using carbon monoxide electrochemical cell, the CO-T1 offers fast and reliable measurements over a long period of time;
- LED indication for sensor operation.
- Measurement range: 0 - 100 ppm CO
- Two-wire 4-20mA linear output signal corresponding to the measurement range
- Long sensor life, up to 5 years
- non-frill design; cost-optimized and loop powered for direct connection to DDCs
- Easy sensor head replacement minimizes long term operating costs
- Single gas (span concentration) calibration.
- Optional LC display (model : CO-T1D)
- Optional measurement range (0 ~ 200ppm or 0 ~ 300ppm).
- Optional terminals for passive temperature sensing elements such as PT100, PT1000 or NTC 10K.
- Optional duct mount housing (-IP65) can effectively sense CO content with air velocity range from minimum of 0.5 m/s.

TECHNICAL SPECIFICATIONS

General

<i>Sensing Method:</i>	<i>Electrochemical</i>
<i>Sampling Method:</i>	<i>Diffusion</i>
<i>Sensor Rated Life:</i>	<i>5 years</i>
<i>Temp Operating Conditions:</i>	<i>0 to 50 °C</i>
<i>Humidity Operating Conditions:</i>	<i>0 to 90 %RH</i>
<i>Storage Conditions:</i>	<i>-40 to 70 °C</i>
<i>Housing Protection rating:</i>	<i>IP44</i>
<i>Housing Material:</i>	<i>ABS FR</i>
<i>Dimension:</i>	<i>140 x 85 x 50 mm</i>

Performance

<i>CO Measurement Range:</i>	<i>0 to 100ppm</i>
<i>Repeatability:</i>	<i>+/-5% of measured value</i>
<i>Linearity:</i>	<i>+/-5% of measured value</i>
<i>Recommended Calibration:</i>	<i>12 months</i>
<i>Response Time:</i>	<i>T90 =< 60 sec</i>
<i>Warm Up time:</i>	<i>less than 2 minutes</i>

Power supply

<i>Input:</i>	<i>21 ~ 32 VDC (+/-10%)</i>
<i>(or</i>	<i>Vin > 11.5 + 0.02 x RLoad)</i>
<i>Power consumption:</i>	<i>≤ 25mA</i>

Outputs

<i>Adjustment/Re-calibration:</i>	<i>Span Adjustment</i>
<i>Output signal:</i>	<i>linear, 4 ~ 20mA</i>
<i>Terminal Wire Size:</i>	<i>16 ~ 24 AWG</i>

CO-T1 WIRING CONNECTIONS

Controller with Voltage Input

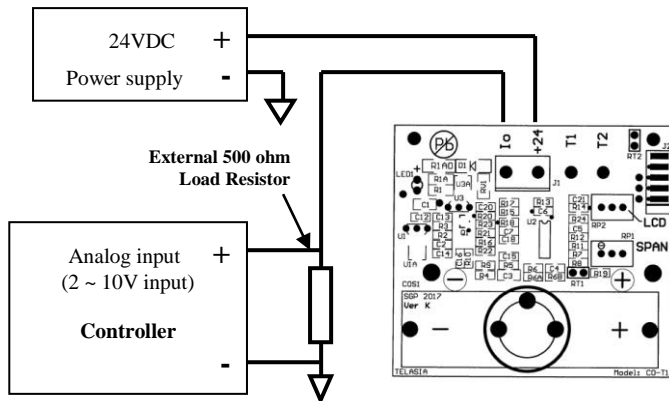

Controller with 4 ~ 20mA Input

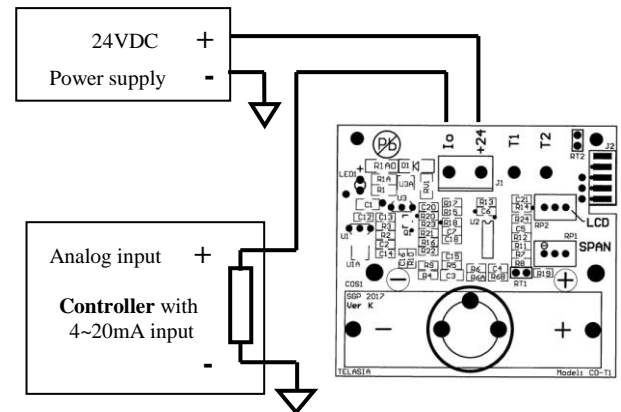

MODEL SELECTION GUIDE

Model	Description	Sensing Range	Wiring
CO-T1	Basic CO sensor/transmitter	0 ~ 100 ppm	2 wires
CO-T1D	With LC Display	0 ~ 100 ppm	2 wires
CO-T1-KS	Duct mount without display	0 ~ 100 ppm	2 wires
CO-T1D-KS	Duct mount, with LC Display	0 ~ 100 ppm	2 wires
CO-T1-200	Model with higher measuring range	0 ~ 200 ppm	2 wires
CO-T1-300	Model with higher measuring range	0 ~ 300 ppm	2 wires
CO-T1-NTC10K	Basic model with passive NTC 10K thermistor	0 ~ 100 ppm	4 wires
CO-T1-Pt1K	Basic model with passive Pt1000 thermistor	0 ~ 100 ppm	4 wires
CO-T1-Pt100	Basic model with passive Pt100 thermistor	0 ~ 100 ppm	4 wires

- Note : Duct mount model in black housing

INSTALLATION

1. Locate a flat surface to mount the sensor enclosure. Use the mounting template provided to mark the three mounting locations. Drill three holes with diameter of 6mm, 40mm deep. Insert the wall plug into the drill holes (*refer to installation manual for details*).
2. Remove the enclosure top cover by pressing the hook at the lower side of the enclosure. Mount the bottom housing onto the flat surface with three wall-plug screws.
3. The cable entry is from upper surface of the enclosure. A PG9 cable gland has been provided. If a GI conduit is used, the entry hole can be enlarged or have the conduit rest on the upper surface of the enclosure.

Pass the electrical wires through the cable gland into the enclosure. **NOTE: BE SURE WIRING IS DONE ACCORDING TO THE LOCAL ELECTRICAL CODE REQUIREMENTS.**

4. Connect the wires to the terminal block as shown on the wiring drawing. NOTE POLARITY. (See wiring drawing). Use 1mm diameter (AWG 22 or AWG24 cable), twisted-pair control wires for the electrical connections. It is recommended that shielded wire be used if it is not being run in metal conduit.
5. Cover the enclosure with the top cover, be sure that the hook is properly secured.

Telasia Symtonic Pte Ltd

• 18, Sin Ming Lane, #07-02, Midview City • Singapore 573960 •

Homepage: www.telasia.net

Phone no.: +65 6659 4882 • Fax no.: +65 6659 4885 • E-mail: contactus@telasia.net